

EXD2010 EX200 Compact Ex d electro-hydraulic positioning and monitoring system

Manufacturer and Approvals Details

The EXD2010 is manufactured and maintained solely by:

Orange Instruments Limited
Lower Farm Road
Moulton Park
Northampton
NN3 6XF
United Kingdom

Telephone +44 (0)1604 790490
Fax +44 (0)1604 790690
email sales@orangeinstruments.co.uk

The EXD2010 system has the following specific approvals:

Name and Type	Compact Ex d electro-hydraulic positioning system EXD2010
Certificate Number	Baseefa09ATEX0327
Specific Marking of Explosion Protection	Ex d IIC Ex tD A21 IP66 T85°C (-40°C ≤ Ta ≤ +59°C)
ATEX Directive Marking	 II 2 G D
Notified body	CE1180

Instructions for Safety

The equipment must be installed by skilled electricians or instructed personnel in accordance with National Legislation and relevant technical standards.

The equipment must NOT be operated in Zone 0 hazardous area.

The technical data listed on the enclosure label must be observed.

Changes to the design of the equipment are not permitted.

The equipment shall only be operated as intended and only in an undamaged condition.

No parts of the equipment are user-serviceable.

EC Declaration of Conformity



Signed

Anthony G. McCormick
ATEX Manager
Orange Instruments Limited

Manufacturer
Orange Instruments Limited
Lower Farm Road
Moulton Park
Northampton NN3 6XF
United Kingdom

Harmonised Standards
EN 60079-0:2006
EN 60079-1:2004

Notified body

Baseefa 1180
Rockhead Business Park
Staden Lane, Buxton
Derbyshire SK17 9RZ
United Kingdom

Equipment description

Electro-hydraulic Positioning System EXD2010
 II 2 G D Ex d IIC Ex tD A21 IP66
T85°C (-40°C ≤ Ta ≤ +59°C)

Tel +44 (0)1604 790490
Fax +44 (0)1604 790690

Orange Instruments Ltd.
Lower Farm Road
Moulton Park
Northampton NN3 6XF UK

Features

- Simple two-step calibration
- 4-20mA current command signals and current or potentiometer feedback signal.
- Actual position 4-20ma calibrated output
- MANUAL mode
- Stepping mode with adjustable ON and OFF times
- Selectable solenoid drive sense for failsafe operation
- Selectable default operation on command signal/feedback signal break
- ESD solenoid output - 24Vdc open drain
- Fault output - 24Vdc open drain
- Hydraulic pump drive controlled by demand or external pressure sensors
- External fault contact monitoring
- Selectable interlock between ESD and fault outputs
- Low power - normal operation less than 1.5W
- Direct mounting within Compact Ex d Enclosure System EX2010 A

The EX200 can be used in any positioning system relying on the on-off control of the position driver including electro-hydraulic actuators and reversing ac motors (with the addition of suitable relays or contactors). The EX200 can accept positional feedback from a three wire potentiometer or a position transducer with a current output. The EX200 is mounted to a special chassis plate and fitted within an Ex d enclosure- EX2010 A. All field and customer wiring is taken through a close-coupled Ex e enclosure. All signals and power supplies are referenced to power supply zero ensuring safe connection to centralised digital control systems (DCS).

Operation

The instrument compares two analogue signals, one representing the desired position (command signal) and the other representing the actual position (feedback signal) of the actuator.

A difference between these two signals will cause one of the EX200 outputs to operate, driving the actuator to the desired position.

A positional Dead-zone may be adjusted to overcome “hunting” problems associated with mechanical overrun of the actuator.

The speed of transit of the actuator can be reduced by selecting the stepping mode that provides independently adjustable on and off times for the open and close solenoid operation.

Physical

The EX200 is mounted on a chassis plate and housed within an Ex d enclosure. The circuit boards are coated with a resist layer that protects the track from moderate condensation and mould growth problems.

Connections within the Ex d are by factory assembled 0.1” connectors and must not be disturbed or re-wired. Initial configuration adjustments are via internal jumper links, usually set to customer requirements on order.

Wiring

A typical wiring diagram is shown on Page 7. Wiring to the Ex e enclosure terminals should be completed by suitably trained personnel taking into account the following notes:

- To ensure RFI compliance the analogue signals should be routed in copper braided screened cables with a fill factor density of at least 0.7.
- The screens should be terminated to the metal of the actuator housing, ideally at a suitable metal cable gland.
- Signal cables should be routed separately from power and switching conductors.

Positioner set-up

Note that some of the positioner functions described here may not be available on all installations e.g. ESD valve solenoid, fault inputs and outputs and hydraulic pump control. Check the accompanying Certificate of Calibration/Conformity for available connections and the factory setting of the jumper links. The solenoid sense and command signal default mode are set up by internal jumper links. If a change is required, then the top cover of the instrument has to be removed to access the links:

- 1) Ensure that there is no hazardous atmosphere. Work in a clean, dry area and use electrostatic discharge protection equipment - a wrist strap and a grounded work mat to make the changes.
- 2) Unscrew the two M2.5 x 5 screws from the top of the instrument to release the top plate..
- 3) Check with drawing 1460-016 for position of jumper links on the base printed circuit board and make the necessary changes. Note that ONLY one selection, + or -, MUST be made for each of the output blocks - LINC LDEC LESD LFLT even if the fault or ESD outputs are not used. Links A-D are selected as required. Unused links should be put on the in-board pin of the block.
- 4) Double check and record the selection then reverse the above procedure to reassemble the EX200.

Setting solenoid operating sense

If the actuator has a spring assisted return to a default position it may be necessary to change the sense of the output solenoid such that at the desired balance point one of the solenoids is energised thus holding the actuator position against the spring. Follow the procedure described in **Positioner set-up** above and select between LDEC +/- and LINC +/- links for the required solenoid sense.

Setting the emergency fail solenoid and fault output sense

These two outputs can respond to failures in the control signals to the system and an external fault input. The EX200 normally sets these two outputs as energised when healthy but the sense of the outputs can be reversed by following the procedure described in **Positioner set-up** above and selecting between LESD +/- and LFLT +/- links for the required outputs.

Setting the command signal break default operation

In the event of a command or feedback signal break or, if selected, an external fault, then the actuator can be forced to one of three default conditions - freeze operation, drive down or drive up. Follow the procedure described in **Positioner set-up** above and select from positions A and B on link block LK1 as follows:

A	B	Function
Out	Out	Freeze mode on signal fault
In	Out	Drive down on signal fault
Out	In	Drive up on signal fault
In	In	Freeze mode again

Setting the emergency solenoid and fault output interlock

Normally the emergency solenoid reacts to control signal breaks in the EX200 and the fault output reacts to a change in state of the external fault input. The external fault input can be set to trigger the emergency solenoid and actuator default mode. Follow the procedure described in **Positioner set-up** above and select from position D on link block LK1 as follows:

D	Function
Out	External fault only triggers fault output
In	External fault triggers fault output, emergency solenoid output and instrument default mode

Setting the self-contained pump control options

The IS200 has an output to control a hydraulic pump supplying power to the actuator. The pump can be configured to operate on demand, when a change in the control signal requires the actuator to move, or under the control of low and high pressure switches in the hydraulic circuit. Follow the procedure described in **Positioner set-up** above and select from position C on link block LK1 as follows:

C	Function
Out	Pump output operates on demand with a 5 second run-on after demand ceases
In	Pump output operates when hydraulic pressure falls below the Low Level switch setting and switches off when the pressure exceeds the High Pressure switch setting.

Setting the stepping option timers

The stepping mode operation is set on the front panel DIL switches but the initial setting should be done prior to first use.

If stepping operation is required, the ON and OFF timers for the open and close solenoids have to be set. This operation is best performed when the actuator hydraulics are isolated but the settings can be trimmed during normal operation of the system.

1. Set DIP switch 3 to ON. This selects timer setting mode. Manual mode is selected automatically.
2. Set DIP switch 1 to ON. *Do not select DIP switches 1 and 2 ON together.* The DECREASE LED will flash and the decrease solenoid will operate. Adjust CAL1 potentiometer to vary the ON time and CAL2 potentiometer to vary the off time. Time the on/off transition over a few cycles to obtain the required result.
3. Press the CALIBRATE button to store the decrease step timer values.
4. Set DIP switch 1 to OFF.
5. Set DIP switch 2 to ON. *Do not select DIP switches 1 and 2 ON together.* The INCREASE LED will flash and the increase solenoid will operate. Adjust CAL1 potentiometer to vary the ON time and CAL2 potentiometer to vary the off time. Time the on/off transition over a few cycles to obtain the required result.
6. Press the CALIBRATE button to store the increase step timer values.
7. Set DIP switch 1 to OFF.
8. Set DIP switch 3 to OFF.
9. The stepping option can be selected by setting DIL switch 4 ON.
10. The above sequence, or part of it, can be selected at any time during normal operation but the actuator will move during the adjustment so hydraulic isolation is advised.

First time operation

WARNING !!

The actuator and associated mechanical equipment connected to it could possibly move in an unpredictable manner during initial calibration. Ensure that all personnel take appropriate precautions.

1. Ensure that any end of travel limit switches and mechanical stops are correctly adjusted before operation.
2. Apply power and provide the 4-20mA command signal. Press the Auto/Manual Switch. Check that the Auto/Manual LED is lit.
3. Operate the Open and Close buttons and confirm that the actuator moves as required.
4. The system must be calibrated before automatic mode is selected.

Calibration

Calibration can only be carried out local to the EX200 unit so it is essential to have purged the area in order to access the EX200 and provide local command signal injection. An alternative is to use the remote DCS to inject and read the actual position signal and transfer the information by handheld radio. If this approach is used ensure that the radio is operated 2m or more from the EX200 and associated wiring.

A command signal is required, normally in the range 4-20mA and a DVM with a 0-200mA range to read the retransmitted position signal.

1. Press the CALIBRATE button, and hold until the CALIBRATE LED goes out. When the button is released, the CALIBRATE LED will flash briefly once per second.
2. The positioner has been switched automatically into Manual, non-stepping mode so use the INCREASE / DECREASE buttons to set the actuator to the required position for the minimum, 4mA command signal. This position can be either fully open or fully close, or indeed anywhere in the mechanical range of the actuator.
3. Set the command signal to 4mA.
4. Adjust the CAL1 potentiometer to give the required output for the chosen position. Note that this not need be 4mA to match the command signal, but can be any value in the range 0.5mA to 22mA.
5. Press and hold the CALIBRATE button until the CALIBRATE LED goes out. Release the button and the CALIBRATE LED will flash twice briefly every second.
6. Use the INCREASE and DECREASE buttons to set the actuator to the required position for the maximum, 20mA command signal. As before, this can be any position within the mechanical range of the actuator.
7. Set the command signal to 20mA.
8. Adjust the CAL1 potentiometer to give the required output for the chosen position. Note that this not need be 20mA to match the command signal, but can be any value in the range 0.5mA to 22mA.
9. Press and hold the CALIBRATE button until the CALIBRATE LED goes out. Release the button to complete the calibration sequence.

General operation

When calibration has been completed the EX200 reverts to automatic mode and to stepping operation if DIL switch 4 is set ON. The actuator should now follow the command signal input and move to the desired position. If there is any instability in positioning, particularly if the hydraulic flow rate is high, then the DEADZONE potentiometer can be set progressively clockwise, half a turn at a time, until stable positioning following a step change can be achieved.

Normal operation - fault detection

If the command signal or the feedback signal goes towards zero (less than 0.5V at the terminals, across any shunt fitted) then the selected fail mode will operate. The actuator will either freeze position, drive down or drive up and the control to the ESD solenoid will be removed. The system will recover to normal operation when the signals are re-instated. If the external fault contact is broken, then the fault output will change, as will the emergency solenoid if LK1 D is linked. The fault condition is reset as soon as the external fault contact is restored. If the unit is in "stepping mode" (DIL switch 4 = ON) then failure mode drive can be either in the selected stepping mode or, if DIL switch 1 is ON, then the unit will fast-fail to its default position.

Self contained operation

If self contained operation is required then a pump starter circuit should be connected to the pump output at terminals 9 and 10. In the case of a dc pump this will be a suitably rated relay and in the case of an ac pump a rated ac contactor. In both cases, the control coils should have a parallel diode to protect the EX200 from switching transients and the pump circuit should have fuse or contact breaker protection. If operation on demand has been selected then the pump will operate for five seconds after the positioner has reached balance. This delay allows for the gradual recharge of any accumulators in the hydraulic circuit.

All calibration parameters are stored within the processor EEPROM and are restored each time the controller is powered up. The controller will respond to current command and feedback signal conditions within 100mS of power being applied to the system.

Maintenance

The outside of the enclosure can be cleaned using a damp cloth. Do not use solvents. Do not open the enclosure whilst a hazard is present.

No internal parts are user serviceable and component level repairs should not be attempted. If a fault occurs then please remove the electronics assembly from the Ex d by unscrewing the M2.5 fixings and disconnecting the 0.1" connectors. Carefully package the assembly in anti-static material and return the unit to the Manufacturers describing the nature and circumstances of the problem.

EX200 appearance

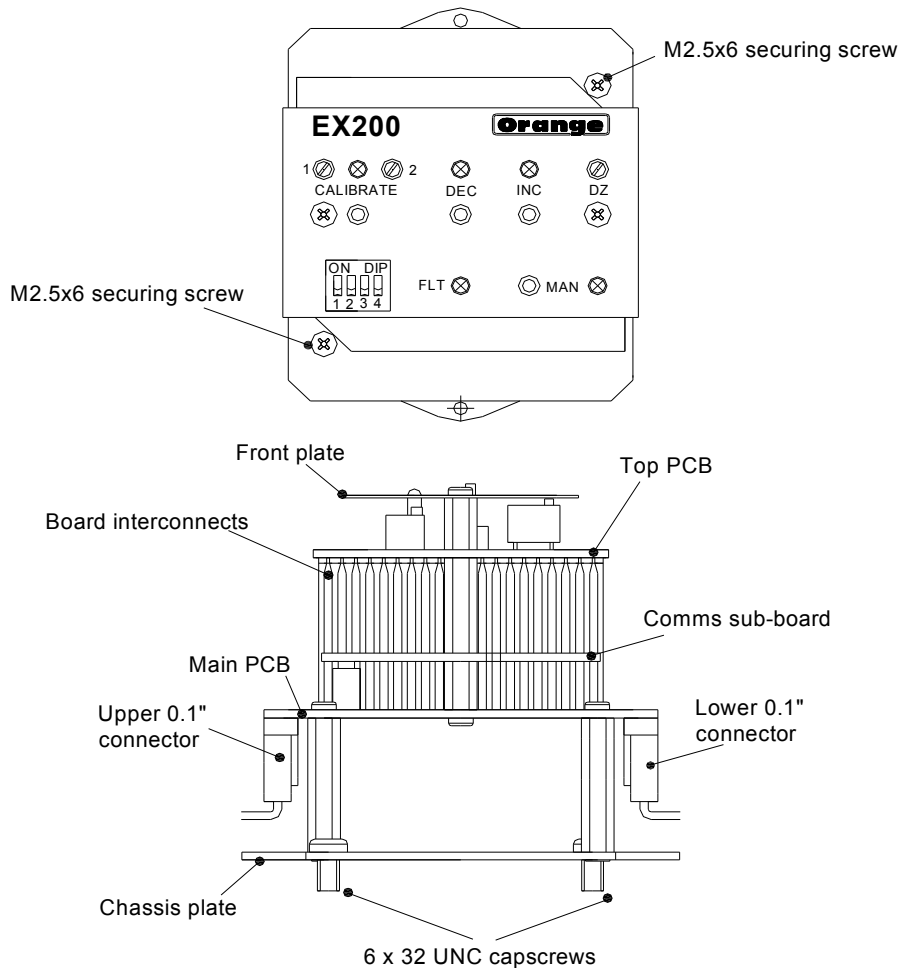

Note – elevation is rotated by 90°

Physical Description

Size with chassis plate – 60mm wide, 73mm high, 80mm deep
Weight with chassis plate – 0.25kg

Specification

COMMAND SIGNAL INPUT

4-20mA nominal 240R input impedance

ANALOGUE POSITION OUTPUT SIGNAL

0.5-22mA can be calibrated anywhere in this range, normally 4-20mA into 400R maximum

FEEDBACK SIGNAL INPUT

Potentiometer 3-wire, any value greater than 200R

4-20mA nominal 240R input impedance

SWITCHED OUTPUTS x 5

Maximum 3A for each output (max controller volt drop at 3A = 0.27V)

INSTRUMENT AND SOLENOID SUPPLY

24V dc nominal (15-36V absolute maximum range) - 1.3W excluding solenoids

55mA maximum current drawn in normal use

USER ADJUSTMENTS

DEC Button to close actuator in Manual

INC Button to open actuator in Manual

MAN Button to toggle auto/manual mode

CAL Button to select Calibrate mode and store calibration data

Timer setting

DIP Switch 1 - Set stepping timers – DECREASE ON and OFF

DIP Switch 2 - Set stepping timers – INCREASE ON and OFF

DIP Switch 3 - No function

DIP Switch 4 - No function

Normal operation

DIP Switch 1 - Select continuous operation on fault if in stepping mode

DIP Switch 4 - No function

DIP Switch 4 - Select stepping mode timers

DIP Switch 4 - Select stepping mode

DZ Potentiometer to set positioning dead zone - clockwise to increase

CAL1 Calibration adjustment and ON time for stepping mode

CAL2 Adjustment for OFF time for stepping mode

INTERNAL LINKS

Output sense - one position + or - *must* be selected for each output, even if the output is unused

LINC + and - Increase solenoid sense links (Factory setting +)

LDEC + and - Decrease solenoid sense links (Factory setting +)

LES D + and - Emergency solenoid sense links (Factory setting +)

LFLT + and - Fault output sense links (Factory setting +)

Other function links

LK1 A Positioner default mode select (Factory setting - out)

LK1 B Positioner default mode select (Factory setting - out)

LK1 C Hydraulic pump control mode select (Factory setting - out)

LK1 D Fault output interlocks (Factory setting - out)

ENVIRONMENT

Operating temperature -40°C to +85°C

Storage temperature -40°C to +115°C

PERFORMANCE - the following applies to the ex200 only, characteristics of the feedback element and actuator system response will have additional effects.

Conversion 10 bit max normal conversion range (4-20mA) = 1 in 800.

O/P switch res. +/-1 bit theoretically, modified to up to +/-5% of span by dead band .

Accuracy (Theo.) 0.125% span based on conversion resolution of 1 in 800.

Accuracy (actual) 0.5% span based on 25% turn down of feedback range.

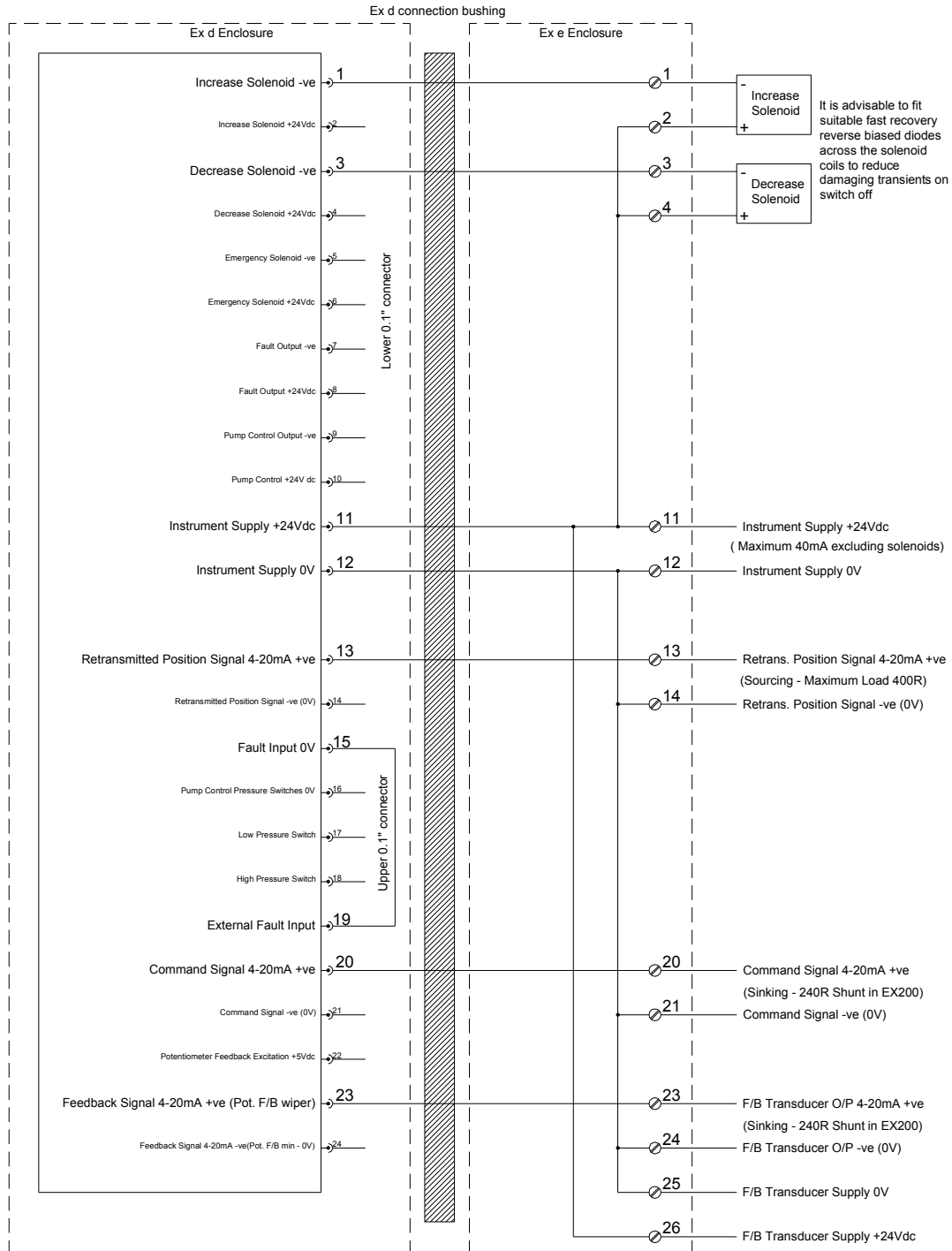

Standard wiring for the EX200 in EXD2010 enclosure assembly

Any variations will be detailed on job-specific documentation.

Orange Instruments Limited.

EX200 Terminal Descriptions

Connections are made via two 12 way 0.1" free sockets. The lower connector is numbered 1-12 from the left and the upper connector is numbered 13-24, again from the left. All 0V points are common to supply 0V.

Lower Conn.	Description	Voltage	Comment
1	Increase Solenoid -ve output	max +36V	Set to 0V to energise solenoid
2	Increase Solenoid +ve output	max +36V	Always at supply potential
3	Decrease Solenoid -ve output	max +36V	Set to 0V to energise solenoid
4	Decrease Solenoid +ve output	max +36V	Always at supply potential
5	Emergency solenoid -ve output	max +36V	Set to 0V to energise solenoid
6	Emergency solenoid +ve output	max +36V	Always at supply potential
7	Fault output -ve output	max +36V	Set to 0V to energise output
8	Fault output +ve output	max +36V	Always at supply potential
9	Pump output -ve output	max +36V	Set to 0V to energise output
10	Pump output +ve output	max +36V	Always at supply potential
11	Instrument Supply +ve	+15 to+36V	
12	Instrument Supply 0V	0V	
Upper Conn.			
13	Actual position signal +ve	+12V	Scaled to actuator movement
14	Actual position signal -ve	0V	set in range 0.5 - 22mA
15	Instrument ground for switched I/Ps	0V	
16	Instrument ground for switched I/Ps	0V	
17	Low pressure switched input	+5V	switch current <0.5mA
18	High pressure switched input	+5V	switch current <0.5mA
19	External fault switched input	+5V	switch current <0.5mA
		connect 15 and 19 if external fault is not used	
20	Command signal +ve (4-20mA)	<+5V	240R shunt
21	Command signal -ve (4-20mA)	0V	
22	Feedback potentiometer maximum	+5V	Potentiometer >200R
23	F/B potentiometer wiper / 4-20mA +ve	<+5V	Current signal optional 240R shunt
24	F/B potentiometer minimum / 4-20mA -ve	0V	