

PFC200

Intrinsically Safe Feedback Transducer Interface

Manufacturer and Approvals Details

The PFC200 is manufactured and maintained solely by:

Orange Instruments Limited
Lower Farm Road
Moulton Park
Northampton
NN3 6XF
United Kingdom

Telephone +44 (0)1604 790490
Fax +44 (0)1604 790690
email sales@orangeinstruments.co.uk

The PFC200 has the following specific approvals

Name and Type	Position Feedback Converter PFC200
Certificate Number	Baseefa 09ATEX00019
Specific Marking of Explosion Protection [Ex ia] IIC T4 (-40°C [Ta [+60°C)	
ATEX Directive Marking	CE II 1 G Ga
Notified body	Baseefa 1180

Features

- Simple configuration and calibration
- Can accept IS LVDT (Positek), potentiometer or IS current source input
- Scaled 4-20mA sourcing or sinking output
- 3 limit switch positions
- 3 safe area open drain limit switch outputs configurable energised/de-energised
- Open drain fault output configurable energised/de-energised
- Option of HART communication (PV actual position) on 4-20mA output signal

EC Declaration of Conformity



Signed

Anthony G. McCormick
ATEX Manager
Orange Instruments

Manufacturer
Orange Instruments Limited
Lower Farm Road
Moulton Park
Northampton NN3 6XF
United Kingdom

Harmonised Standards
EN 60079-0:2006
EN 60079-11:2007

Other Standards
EN 60079-26:2007

Notified body
Baseefa 1180
Rockhead Business Park
Staden Lane, Buxton
Derbyshire SK17 9RZ
United Kingdom

Equipment description
Position Feedback Converter PFC200
CE II 1 G Ga
[Ex ia] IIC T4 (-40°C£Ta£+60°C)



Tel +44 (0)1604 790490
Fax +44 (0)1604 790690

Orange Instruments Ltd.
Lower Farm Road
Moulton Park
Northampton NN3 6XF UK

Operation

The PFC200 Feedback Converter is designed to scale and transmit the signal from a Zone 0 position transducer to a safe area 4-20mA signal. The PFC200 must be located within a suitable safe area. The unit runs from a 24V +/-10% supply and consumes 4W power

Physical

The IS200 HART is housed in a small DIN rail mounted polycarbonate enclosure measuring 75 x 55 x 110h and is protected to IP40. The circuit boards are coated with a resist layer that protects the track from moderate condensation and mould growth problems. Connections are via screw terminals with a capacity of 2.5mm² but the use of ferrules or crimps is recommended. All routine adjustments are accessible on the front panel of the enclosure.

Wiring

To comply with the IS Certification the PFC200 must be wired as shown in the circuit on Page x. Wiring should be completed by suitably trained personnel taking into account the following notes:

- To ensure RFI compliance the analogue signals MUST be routed in copper braided screened cables with a fill factor density of at least 0.7.
- The screens should be terminated to the metal of the actuator housing, ideally at a suitable metal cable gland.
- Signal cables should be routed separately from power and switching conductors.
- Ensure that all supply and signal barriers are present and correctly connected and supplied with power from the safe area.

Converter set-up

The limit switch and fault output sense and set as power-up adjustments as described below. Calibration and signal damping can be undertaken at any time using the procedures described below. Selection of the loop mode of the output, sinking or sourcing, is normally a factory setting option selected on order.

Setting limit switch operating sense

Start the procedure by arranging all three switches to be in their mid-travel or uncovered states.

1. Hold in the SW4 pushbutton and apply power to the converter.
2. The LD4 will light continuously and pressing SW1, 2 or 3 pushbuttons will cause the appropriate LEDs LD1, 2 or 3 to “toggle” on and off. LED on indicates a conducting open drain output for that switch.
3. Select the required switch output status.
4. When satisfied press the SW4 pushbutton again.

Normal operation will commence. Remove the power if the fault output sense has to be set.

Setting fault output operating sense

Start the procedure by arranging that the position transducer be disconnected, simulating a fault condition. Note that the transducer should always have some mechanical and associated electrical range above and below the normal range of valve movement.

1. Hold in the SW1 pushbutton and apply power to the converter.
2. The LD1 will light continuously and pressing SW4 pushbutton will cause the LD4 to “toggle” on and off. LED on indicates a conducting open drain output for the fault output.
3. Select the required fault output status.
4. When satisfied press the SW1 pushbutton again.

Remove power and reconnect the position transducer.

Calibration

There must be some method available to move the valve associated with the position transducer. Ensure that the position transducer has been reconnected since the setting of the fault output sense adjustment.

1. Press and hold the SW4 pushbutton. LD4 will light.
2. Hold SW4 until the LD4 goes out. When the button is released, the LD4 will flash briefly once per second.
3. Move the valve to the position to be associated with a low-end, say 4mA, actual position signal.
4. Adjust the P1 potentiometer to give the required output for the chosen position. Note that this not need be 4mA but should be above 2mA and below the required high-end signal. The limit switch outputs will be active during the whole calibration process to aid position sensing.
5. Press and hold the SW4 pushbutton until LD4 goes out. Release the button and the CALIBRATE LED will flash twice briefly every second.
6. Move the valve to the position to be associated with a high-end, say 20mA, actual position signal.
7. Adjust the P1 potentiometer to give the required output for the chosen position. Note that this not need be 20mA but should be below 21mA and above the required low-end signal. Again the limit switch outputs will be active during the whole calibration process to aid position sensing.
8. Press and hold the SW4 pushbutton. LD4 will light.
9. Hold SW4 until the LD4 goes out.

General operation

When calibration is complete and at any time that the PFC200 is re-powered normally, the output will show a value between the calibrated end points, the limit outputs (and LD1, 2, 3) will reflect the state of the limit switches and the fault output (LD4) will show the configured healthy position.

If the transducer becomes faulty or disconnected and thus gives an input to the PFC200 less than 1% or more than 99% of its absolute range, then fault output will change state and the loop output will fall to below 2mA. Normal operation will be restored immediately the transducer is restored to working order.

Potentiometer P2 can be adjusted to give a timed average output based on samples taken every 200mS. If P2 is fully anticlockwise, the current transducer position is output with no integration. A maximum of 5 seconds integration is available.

Maintenance

No internal parts are user serviceable and component level repairs should not be attempted. If a fault occurs then please return the unit to the Manufacturers describing the nature and circumstances of the problem.

PFC200 appearance and dimensions

Enclosure can be fitted on Standard Symmetric EN50054 component mounting rail– 35 x 7.5. Use a purpose-designed tool for adjusting small potentiometers.

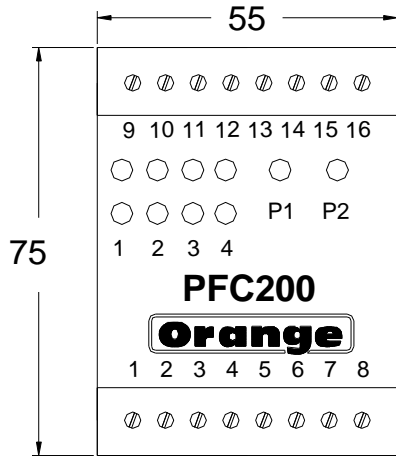

PFC200 - Top view

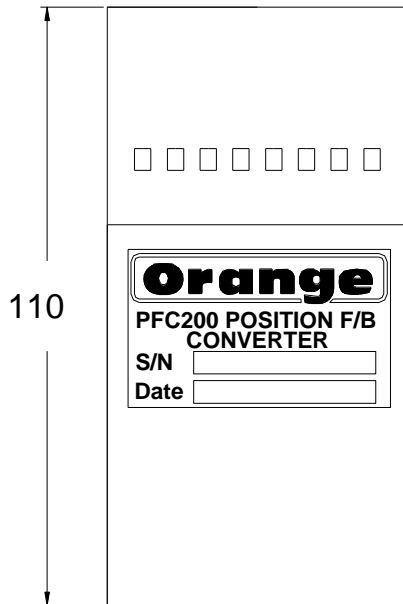

PFC200 - End view
(Terminals 1-8 Ex ia)

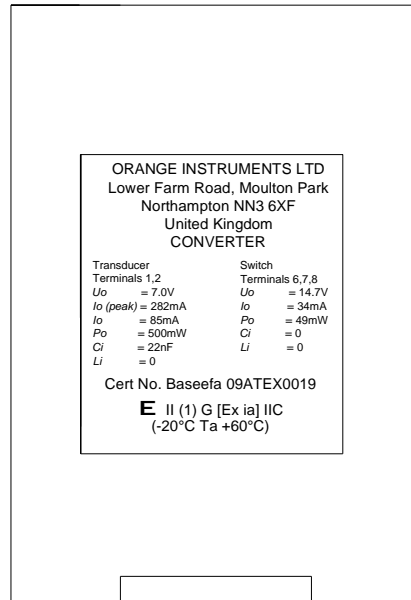

PFC200 - LHS - data label

Zone of Operation

The PFC200 must be mounted within a suitable safe area. It has an intrinsically safe interface and can be connected to suitably certified equipment meeting the following specification:

CE [Ex ia] IIC T4 (-20°C [Ta [+60°C) Ta = ambient temperature

IEC CENELEC

Zone 0 – continuous hazard present.

Gas Group – IIC (hydrogen, acetylene, carbon disulphide)

Surface temperature – T4 135°C – Ambient temperature -40°C to +60°C

North America

Division 1

Class 1A (Hydrogen)

Class 1B (acetylene)

Physical Description

Size – 55mm wide, 75mm high, 110mm deep

Weight – 0.25kg

Enclosure – polycarbonate

Equipment rating – IP40

Specification

POSITION TRANSDUCER INPUT – Zone 0 device

There are three possible inputs. Only one input can be used at any one time:

1. Positek position transducer Type **Intrinsically Safe LIPS® X111**
2. Simple 3-wire potentiometer
3. Suitable IS sourcing current signal – input shunt 240R

LIMIT SWITCH INPUTS – Zone 0 devices

1. Simple contact closures pulled up to internal 5V.
2. 2-wire proximity switch

ACTUAL POSITION OUTPUT SIGNAL

Sinking or sourcing in the range of 2mA to 21mA

1. Sinking – maximum excitation 28V dc
2. Sourcing – maximum load 300R

LIMIT SWITCH AND FAULT OUTPUTS

Open drain outputs referenced to instrument supply 0V and clamped to instrument supply +24Vdc. Maximum load 1A.

INSTRUMENT SUPPLY

24V dc +/- 10% safe area supply

USER ADJUSTMENTS

SW1/LD1 Limit switch 1 set up and indication

SW2/LD2 Limit switch 1 set up and indication

SW3/LD3 Limit switch 1 set up and indication

SW4/LD4 Normal – Fault indicator
Calibration start and indicator
Power up – Fault sense select

P1 Calibration adjustment

P2 Signal damping level

PERFORMANCE - the following applies to the PFC200 only, characteristics of the feedback element will have additional effects.

Conversion 12 bit max normal conversion range (4-20mA) = 1 in 4000.

Signal damping 25 x 200mS steps

Orange Instruments Limited.

Drwg. No.: 3687-009 Issue A Date 01/10/2008 Page 5 of 7

Issue A – Origination

Issue B – Note added about separation of two IS terminal groups – 24/03/2009 AGM

ATEX Certified Equipment - Change Authority ATEX Manager ONLY

Typical installation wiring diagram

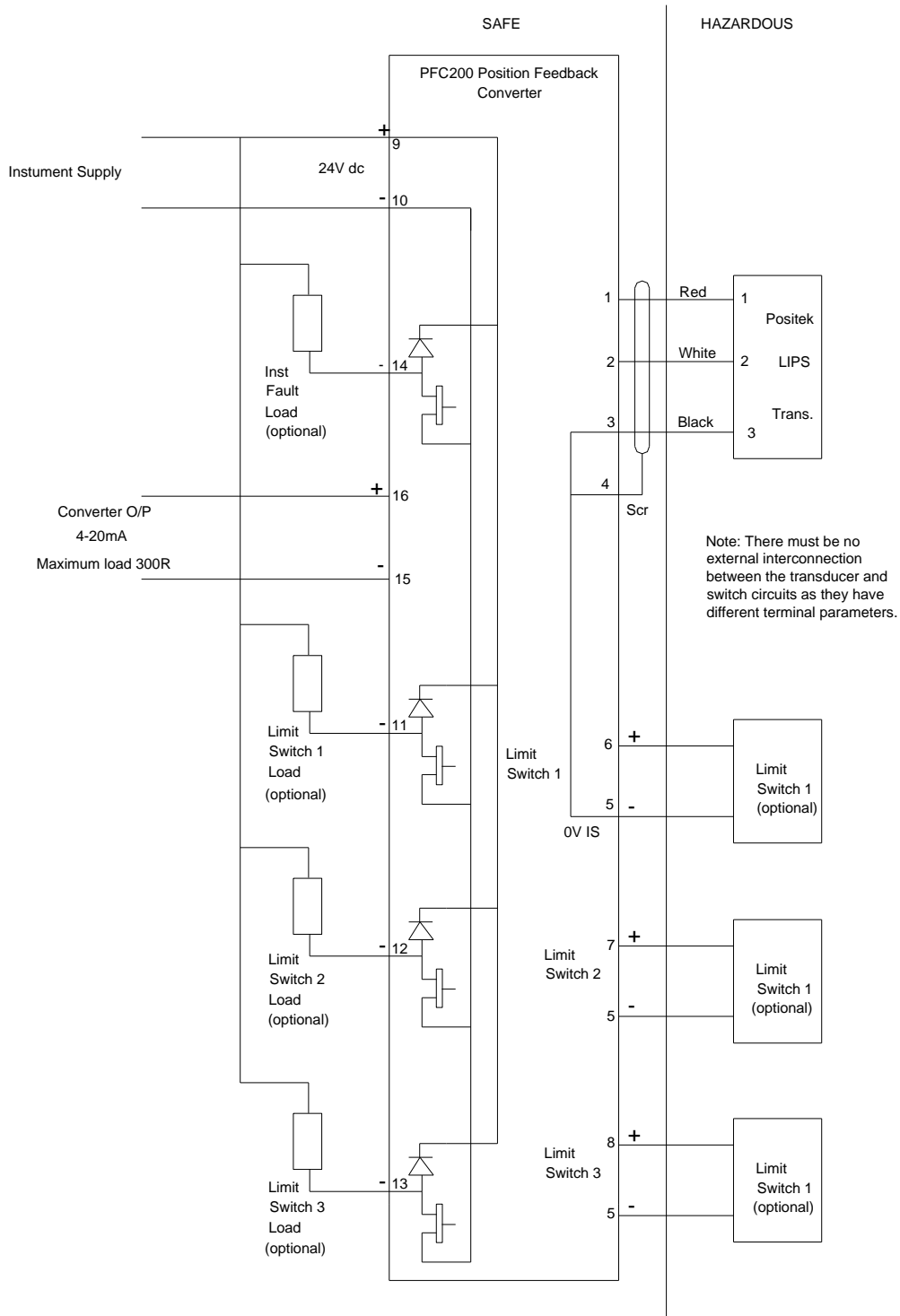

Orange Instruments Limited.

Drwg. No.: 3687-009 Issue A Date 01/10/2008 Page 6 Of 7

Issue A – Origination

Issue B – Note added about separation of two IS terminal groups – 24/03/2009 AGM

ATEX Certified Equipment - Change Authority ATEX Manager ONLY

PFC200 Terminal Descriptions

All wiring to hazardous area circuits should be in suitable braided or armoured cable with blue outer casing or sleeving. Terminate braids *at one end only* to local metal enclosures.

Terminals 1-8 must be connected to hazardous area circuits only

Terminal	Description	Voltage	Comment
1	Positek LIPS +ve excitation, Pot. Max	<7.5V	Fixed value 5V
2	Positek LIPS signal output, Pot. Wiper	<7.5V	0-5V
3	Positek LIPS 0V, Pot. Min	0V	Ground (Hazardous Area)

Note: There must be no external interconnection between circuits to Terminals 1-3 and 4-8 as the terminal groups have different parameters.

4	IS circuits ground	0V	Ground (Hazardous Area)
5	IS circuits ground, Limit switch return	0V	Ground (Hazardous Area)
6	Limit switch 1 input	<7.5V	Switched to IS 0V
7	Limit switch 2 input	<7.5V	Switched to IS 0V
8	Limit switch 3 input	<7.5V	Switched to IS 0V

Terminals 9-16 must be connected to safe area circuits only

9	Instrument Supply +ve	<30V	24V +/-10%
10	Instrument Supply 0V	0V	Ground (Safe area)
11	Limit switch 1 output	<30V	Referenced to Inst. Supply 0V
12	Limit switch 2 output	<30V	Referenced to Inst. Supply 0V
13	Limit switch 3 output	<30V	Referenced to Inst. Supply 0V
14	Fault output	<30V	Referenced to Inst. Supply 0V
15	Output signal -ve 4-20mA	<12V	Default is sourcing signal Sinking option < 30V
16	Output signal +ve 4-20mA	<12V	